

CBT BEAM SENSOR

SUPPLEMENTARY INFORMATION

The CBT is a hermetically sealed high accuracy extensometer sensor. It is a highly sensitive transducer that measures minute changes in length in the elevator cross beam when the load is varied. It is made from stainless steel and is fully welded and sealed.

The CBT Sensor has been designed to work in conjunction with the Garan EWS 102 Elevator Load Weighing Device:

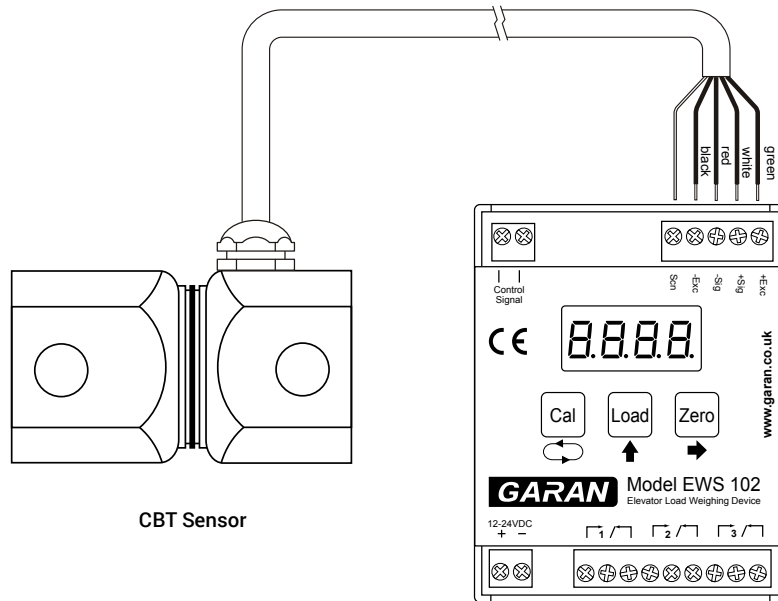

CBT Sensor

Location

For best accuracy, mount the CBT on the cross beam close to the hitch plate, this is where the largest deflection will occur causing the sensor to minutely deflect in bending.

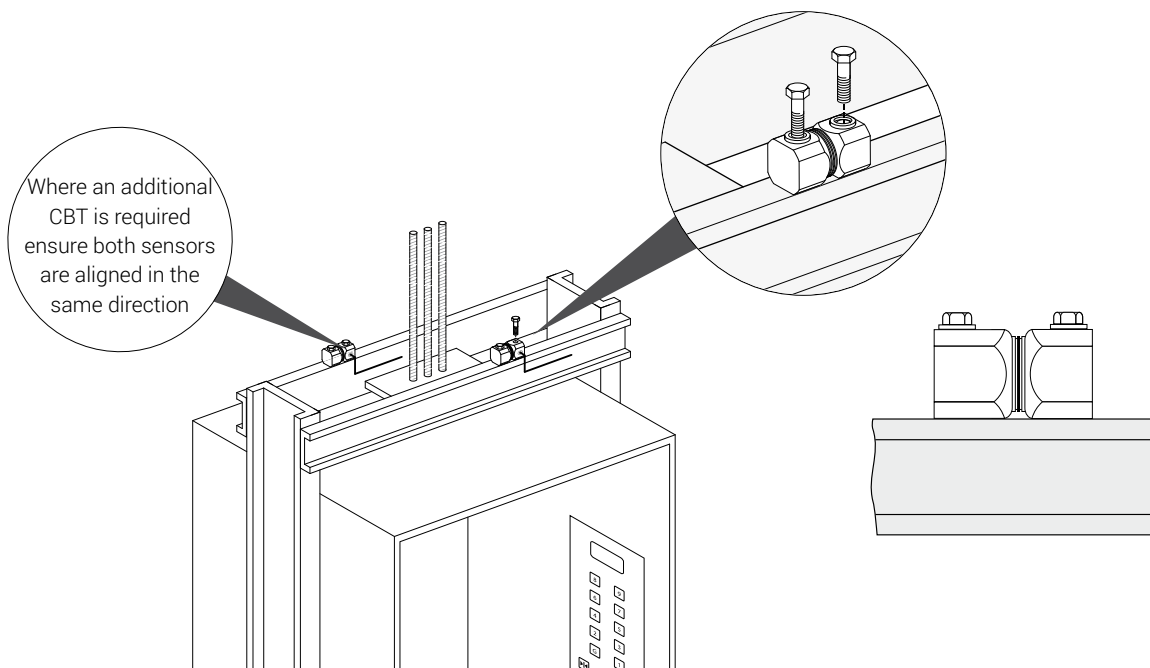

CBT BEAM SENSOR

SUPPLEMENTARY INFORMATION

Application

The CBT is mounted using 2 x M10 high tensile bolts. The fixing options are:

- Through hole: bolts through the sensor and cross beam and secured with nuts on the opposite side
- Drill & tap: bolts through the sensor and into threaded holes in the structure

Surface preparation

Having drilled the cross beam to accept the M10 bolts it is essential that the contact surfaces is flat, clean and free from rust, paint and surface scale. These must be removed carefully by an abrasive process, such as grinding or filing. It is also essential to ensure that the drilled M10 holes are deburred to ensure a flat surface.

Installation

Mark and drill 2 holes at a distance of 50 mm between centres (see CBT sensor alignment in the drawing above)

- **Through hole:** drill 10.5 mm diameter.
- **Drill and tap:** drill holes 8.5 mm diameter and tap M10 x 1.5 pitch.
- Place the CBT over the holes, insert the bolts and washers with and tighten finger-tight
- Carefully tighten the bolts alternatively and in stages to the recommended torque value of 50-80 Nm

Through-Hole

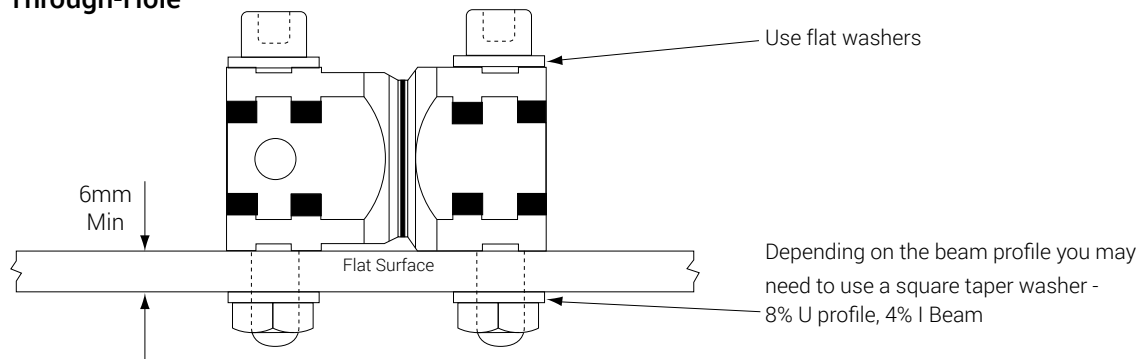

Drill & Tap

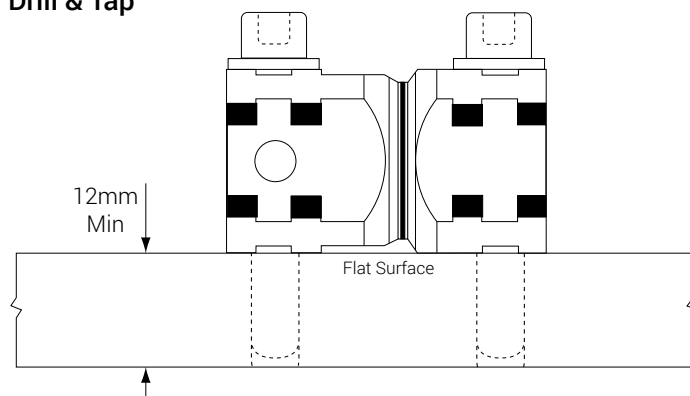

Wiring

Once the CBT sensor has been fitted to the beam, terminate the cable at the EWS 102 Elevator Load Weighing Device as shown in the diagram at the beginning of the document.